

HURRICANE

BUBBLE HAZE
User Manual

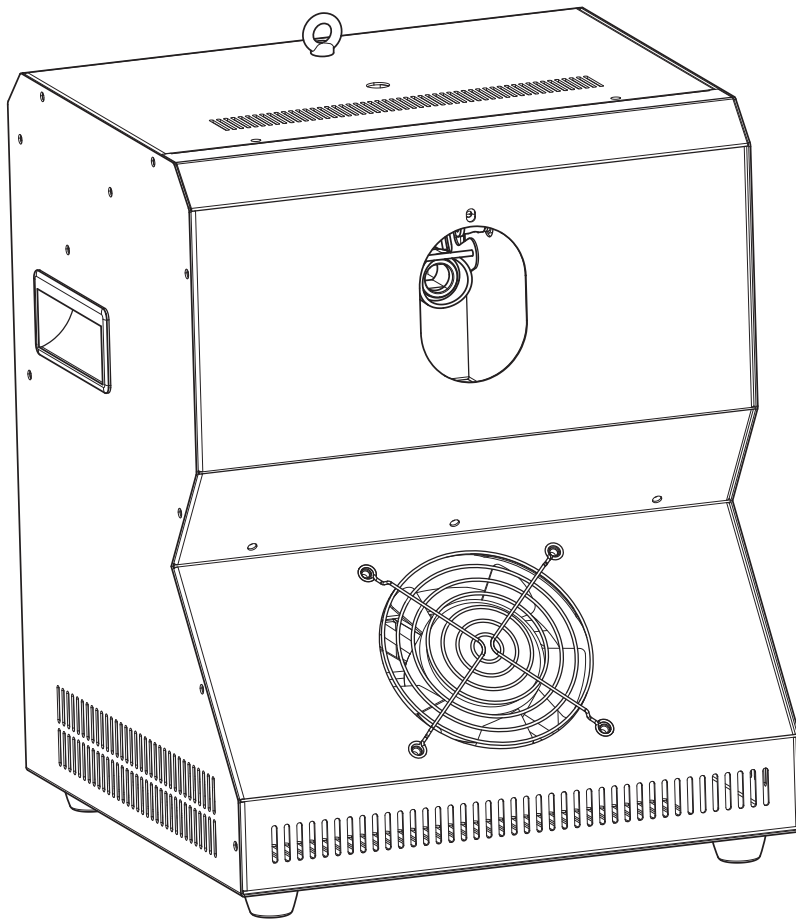

CHAUVET

TABLE OF CONTENTS

1. Before You Begin	1
What Is Included	1
Unpacking Instructions	1
Claims	1
Text Conventions	1
Symbols	1
Disclaimer	1
Intellectual Property	1
Safety Notes.....	2
2. Introduction	3
Product Overview.....	3
Product Dimensions.....	3
3. Setup	4
AC Power	4
Fuse Replacement.....	4
Mounting	5
Orientation.....	5
Rigging.....	5
4. Operation	6
Control Panel Operation.....	6
Menu Map	6
Configuration (DMX)	6
Starting Address.....	6
DMX Channel Assignments and Values	7
Configuration (Standalone)	7
Bubble Output	7
Haze Volume.....	7
Blower Fan Speed.....	7
Master/Slave Mode	8
5. Maintenance	9
Bubble Cleaning Mode.....	9
Hazer Maintenance	10
Storage.....	10
Powering Off the Product for Transport	10
6. Technical Specifications	11
Returns	12
Contact Us	13

1. Before You Begin

What Is Included

- Hurricane Bubble Haze
- Power Cord
- Quick Reference Guide

Unpacking Instructions

Carefully unpack the product immediately and check the container to make sure all the parts are in the package and are in good condition.

Claims



If the box or the contents (the product and included accessories) appear damaged from shipping, or show signs of mishandling, notify the carrier immediately, not Chauvet. Failure to report damage to the carrier immediately may invalidate your claim. In addition, keep the box and contents for inspection.

For other issues, such as missing components or parts, damage not related to shipping, or concealed damage, file a claim with Chauvet within 7 days of delivery.

Text Conventions

Convention	Meaning
1–512	A range of values
50/60	A set of values of which only one can be chosen
Settings	A menu option not to be modified
<ENTER>	A key to be pressed on the product's control panel
ON	A value to be entered or selected

Symbols

Symbol	Meaning
	Critical installation, configuration, or operation information. Not following these instructions may make the product not work, cause damage to the product, or cause harm to the operator.
	Important installation or configuration information. The product may not function correctly if this information is not used.
	Useful information.

Disclaimer

Chauvet believes that the information contained in this manual is accurate in all respects. However, Chauvet assumes no responsibility and specifically disclaims any and all liability to any party for any loss, damage or disruption caused by any errors or omissions in this document, whether such errors or omissions result from negligence, accident or any other cause. Chauvet reserves the right to revise the content of this document without any obligation to notify any person or company of such revision, however, Chauvet has no obligation to make, and does not commit to make, any such revisions. Download the latest version from www.chauvetdj.com.

Intellectual Property

The works of authorship contained in this manual, including, but not limited to, all design, text and images are owned by Chauvet.

© Copyright 2019 Chauvet & Sons, LLC. All rights reserved.

Electronically published by Chauvet in the United States of America.

CHAUVET, the Chauvet logo, and Hurricane Bubble Haze are registered trademarks or trademarks of Chauvet & Sons LLC (d/b/a Chauvet and Chauvet Lighting) in the United States and other countries. Other company and product names and logos referred to herein may be trademarks of their respective companies.

Patent Pending.

Safety Notes



- This product is not intended for permanent installations.
- Always connect the product to a grounded circuit to avoid the risk of electrocution.
- Always disconnect this product from the power source before cleaning it or replacing the fuse.
- Make sure the power cord is not crimped or damaged.
- Never disconnect the power cord by pulling or tugging on the cord.
- Make sure there are no flammable materials close to the unit while operating
- Do not touch the output nozzle on this product. It is very hot during operation and it may remain hot for several hours after turning the unit off.
- Do not drink the haze fluid or the bubble fluid. If you do, call your local emergency service (911 in the US) for help.
- Do not add perfume, alcohol, gasoline, or any other flammables to the haze fluid.
- Depending on the amount of haze generated, all haze machines may set off smoke detectors.
- In certain environments, haze fluid-based machines may leave a slippery residue on floors and surfaces.
- Do not use for space heating purposes.
- Do not obstruct the bubble wands or leave machine unattended.
- Use only CHAUVET DJ water-based haze fluid.
- Use only CHAUVET bubble fluid (BJG) which has been specially formulated for use with the Hurricane Bubble Haze.
- Do not overfill; spillage may occur. Always mount on a flat, level surface.
- Do not leave unused fluid in the reservoir for an extended period. The fluid may thicken in the reservoir.
- Drain the tank before transporting the product.
- Use caution: continuous use may cause slippery surfaces.
- Always make sure that the voltage of the outlet to which you are connecting the product is within the range stated in the decal or rear panel of the product.
- This product is for indoor use only! To prevent risk of fire or shock, do not expose this product to rain or moisture.
- Always install this product in a location with adequate ventilation, at least 20 in (50 cm) from adjacent surfaces.
- Be sure that no ventilation slots on the unit's housing are blocked.
- Never connect this product to a dimmer or rheostat.
- Make sure to replace the fuse with another of the same type and rating.
- Never carry the product from the power cord or any moving part. Always use the hanging/mounting bracket.
- The maximum ambient temperature (Ta) is 104 °F (40 °C). Do not operate this product at higher temperatures.
- In the event of a serious operating problem, stop using the product immediately.
- Never try to repair this product. Repairs carried out by unskilled people can lead to damage or malfunction. Please contact the nearest authorized technical assistance center.
- To eliminate unnecessary wear and improve its lifespan, during periods of non-use completely disconnect the product from power via breaker or by unplugging it.



Keep this User Manual for future use. If the product is sold to someone else, be sure that they also receive this document.

2. Introduction

Product Overview

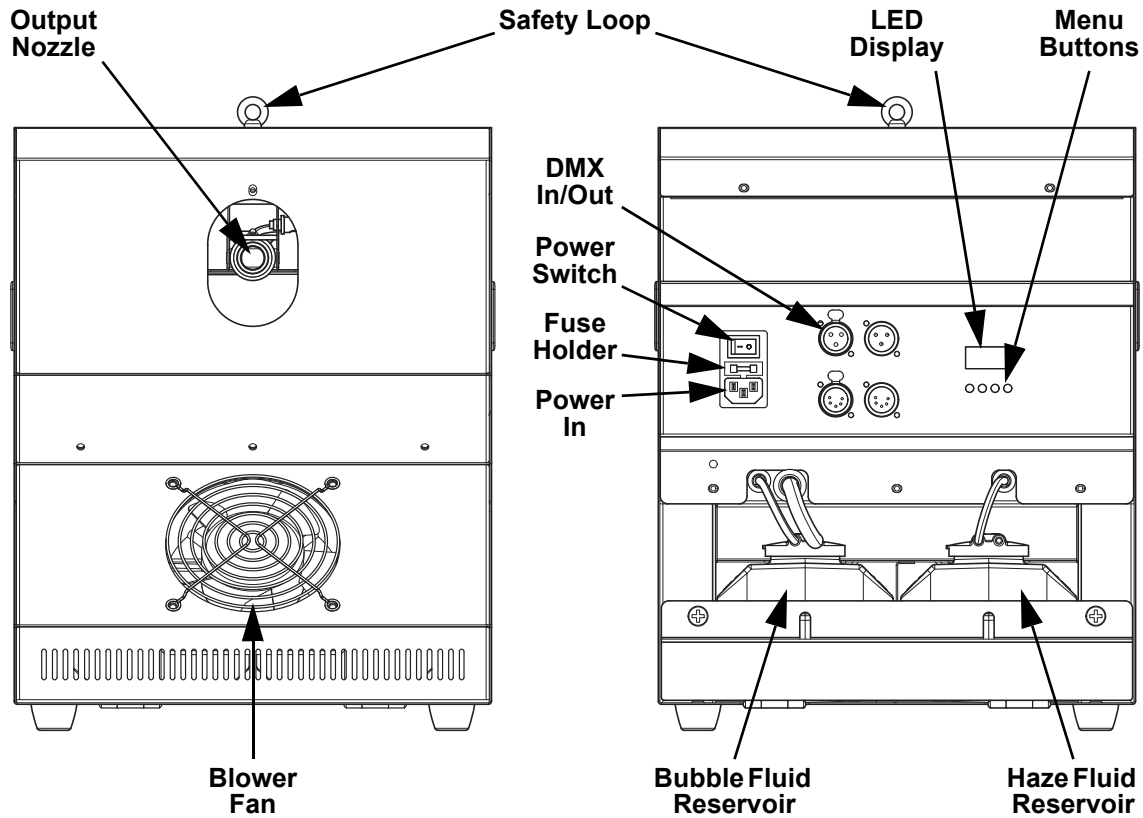

Product Dimensions

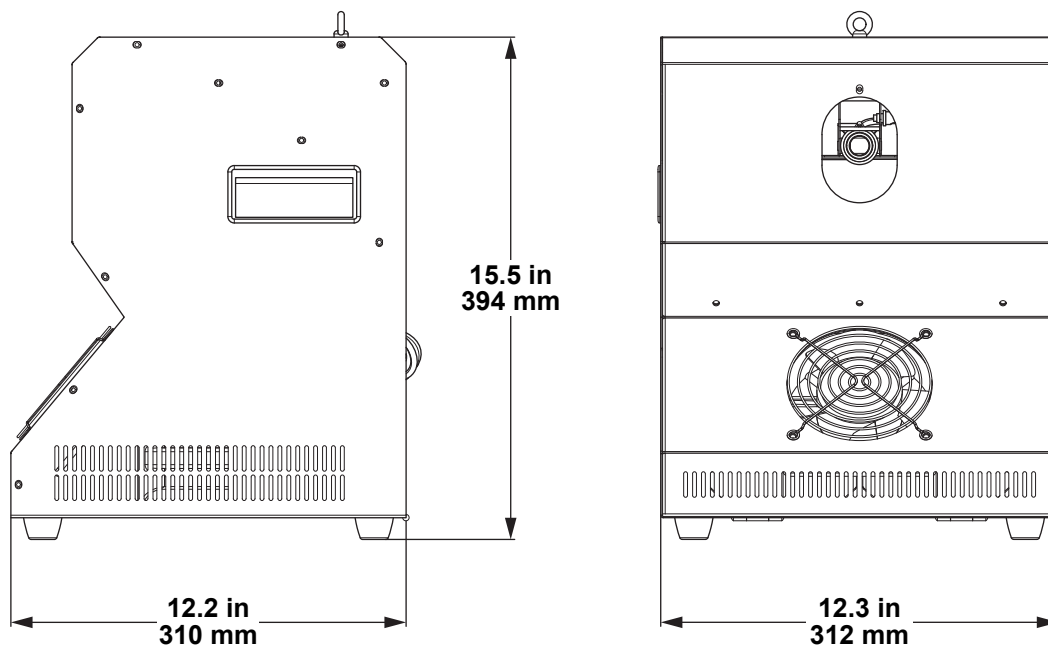

3. Setup

AC Power

The Hurricane Bubble Haze has a fixed voltage power supply and it can work with an input voltage of either 120 VAC, 60 Hz or 230 VAC, 50 Hz, depending on the specific model.

To determine the product's power requirements (circuit breaker, power outlet, and wiring), use the current value listed on the label affixed to the product's back panel, or refer to the product's specifications chart.

The listed current rating indicates the product's average current draw under normal conditions.



- **Always connect the product to a protected circuit (a circuit breaker or fuse). Make sure the product has an appropriate electrical ground to avoid the risk of electrocution or fire.**
- **To eliminate unnecessary wear and improve its lifespan, during periods of non-use completely disconnect the product from power via breaker or by unplugging it.**



Never connect the product to a rheostat (variable resistor) or dimmer circuit, even if the rheostat or dimmer channel serves only as a 0 to 100% switch.

Fuse Replacement

1. Disconnect the product from power.
2. Wedge the tip of a flat-head screwdriver into the slot of the fuse holder.
3. Pry the fuse holder out of the housing.
4. Remove the blown fuse from the holder and replace with a fuse of the exact same type and rating.
5. Insert the fuse holder back in place and reconnect power.

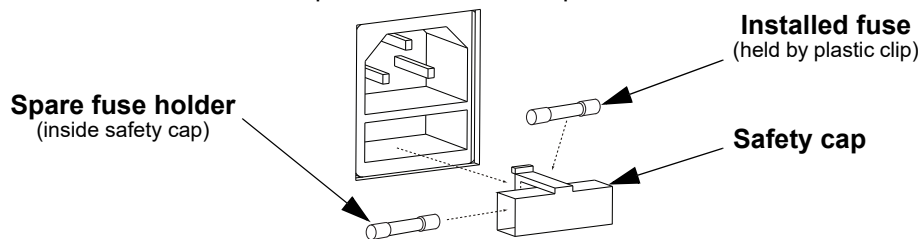

Disconnect the product from the power outlet before replacing the fuse.

Mounting

Before mounting the product, read and follow the safety recommendations indicated in the [Safety Notes](#).

Orientation

The Hurricane Bubble Haze may be mounted in any position; however, make sure adequate ventilation is provided around the product.

Rigging

- Before deciding on a location, always make sure there is easy access to the product for maintenance and programming.
- Make sure adequate ventilation is provided around the product.
- Make sure that the structure or surface onto which you are mounting the product can support the product's weight. (see the [Technical Specifications](#))
- When mounting the product overhead, always use a safety cable. Mount the product securely to a rigging point, whether an elevated platform or a truss.
- When rigging the product onto a truss, use a mounting clamp of appropriate weight capacity.
- When power linking multiple products, mount the products close enough for power linking cables to reach.
- This product may NOT be tilted. This product should be level at all times.

Mounting Diagram

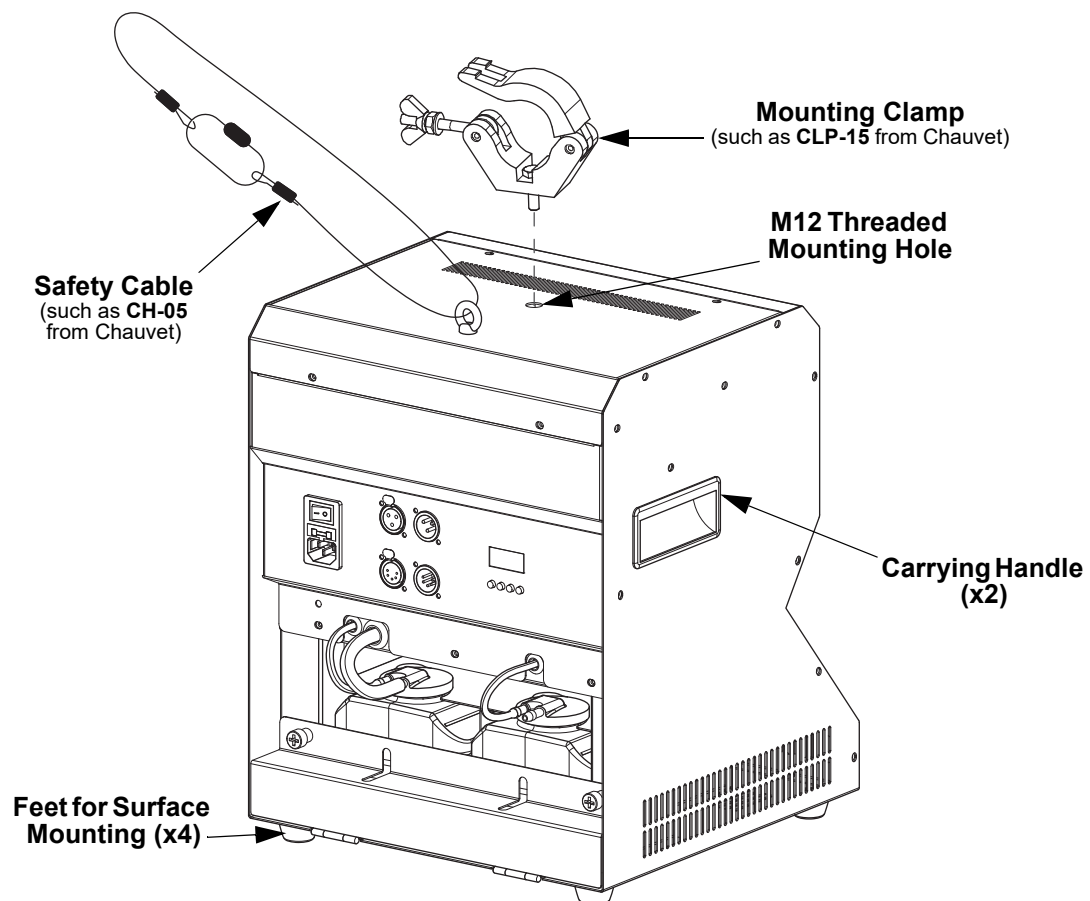

This product may NOT be tilted. This product should be level at all times.

4. Operation

Control Panel Operation

To access the control panel functions, use the four buttons located underneath the display. Refer to the [Product Overview](#) to see the button locations on the control panel.

Button	Function
<MENU>	Exits from the current menu or function
<UP>	Navigates upwards through the menu list or increases a selected numeric value
<DOWN>	Navigates downwards through the menu list or decreases a selected numeric value
<ENTER>	Enables the currently displayed menu or sets a selected value into the selected function

Menu Map

Mode	Programming Levels		Description
DMX Address	Addr	1–512	Sets the DMX starting address
Bubble Output	b	oFF	Bubble output off
		on	Bubble output on
Haze Volume	H	0–100	Haze volume, low to high
Blower Fan Speed	F	0	Blower fan off
		1–3	Blower fan speed, 1 (low) to 3 (high)
Bubble Cleaning Mode	CLE	oFF	Bubble Cleaning Mode off
		on	Cleaning mode on



- For the Bubble Cleaning Mode, use clean water to rinse out the bubble mechanism.
- Through the display menu, the Bubble Cleaning Mode will run for 2 minutes before reverting to standby.



Use the Bubble Cleaning Mode after every use.

Configuration (DMX)

The Hurricane Bubble Haze works with a DMX controller. Information about DMX is in the CHAUVET DMX Primer, which is available from the Chauvet website http://www.chauvetlighting.com/downloads/DMX_Primer_rev05_WO.pdf.

Starting Address

When selecting a starting DMX address, always consider the number of DMX channels the selected DMX mode uses. If you choose a starting address that is too high, you could restrict the access to some of the product's channels.

The Hurricane Bubble Haze uses 4 DMX channels, which defines the highest recommended address as **509**.

If you are not familiar with the DMX protocol, download the DMX Primer from www.chauvetdj.com.

To select the starting address, do the following:

1. Press <MENU> repeatedly until **Addr** shows on the display.
2. Press <ENTER>.
3. Use <UP> or <DOWN> to select the starting address, from **1–512**.
4. Press <ENTER>.

DMX Channel Assignments and Values

Channel	Function	Value	Percent/Setting
1	Bubble Output	000 ⇔ 010	Off
		011 ⇔ 255	On
2	Haze Volume	000 ⇔ 010	No function
		011 ⇔ 255	Haze volume, low to high
3	Blower Speed	000 ⇔ 010	Blower fan off
		011 ⇔ 100	Blower fan speed low
		101 ⇔ 200	Blower fan speed medium
		201 ⇔ 255	Blower fan speed high
4	Bubble Cleaning Mode	000 ⇔ 010	No function
		011 ⇔ 255	Bubble Cleaning Mode on (bubble pump only)



- For Continuous Output mode, set channel 2 from 011 ⇔ 126.
- Fluid consumption will be significantly increased during Continuous Output mode.



- For the Bubble Cleaning Mode, use clean water to rinse out the bubble mechanism.
- Through the DMX, the Bubble Cleaning Mode will run indefinitely.



Use the Bubble Cleaning Mode after every use.

Configuration (Standalone)

Set the product in the standalone mode to control without a DMX controller.



Never connect a product that is operating in any standalone mode to a DMX string connected to a DMX controller. Products in standalone mode may transmit DMX signals that could interfere with the DMX signals from the controller.

Bubble Output

To turn the bubble output of the Hurricane Bubble Haze on or off, follow the instructions below.

1. Press **<MENU>** repeatedly until **b** shows on the display.
2. Press **<ENTER>**.
3. Use **<UP>** or **<DOWN>** to select from **Off** or **on**.
4. Press **<ENTER>**.

Haze Volume

To adjust the haze volume of the Hurricane Bubble Haze, do the following:

1. Press **<MENU>** repeatedly until **H** shows on the display.
2. Press **<ENTER>**.
3. Use **<UP>** or **<DOWN>** to increase or decrease the haze volume, from **0–100**.
4. Press **<ENTER>**.

Blower Fan Speed

To adjust the blower fan speed of the Hurricane Bubble Haze, follow the instructions below.

1. Press **<MENU>** repeatedly until **F** shows on the display.
2. Press **<ENTER>**.
3. Use **<UP>** or **<DOWN>** to increase or decrease the blower fan speed, from **0–3**.
4. Press **<ENTER>**.

Master/Slave Mode

The Master/Slave mode allows a single Hurricane Bubble Haze product (the “master”) to control the actions of one or more Hurricane Bubble Haze products (the “slaves”) without the need of a DMX controller. The master product will be set to operate in standalone mode, while the slave products will be set to operate in Slave mode. Once set and connected, the slave products will operate in unison with the master product.

Configure the products as indicated below.

Slave products:

1. Press **<MENU>** repeatedly until **Addr** shows on the display.
2. Press **<ENTER>**.
3. Set the DMX address to **1**.
4. Connect the DMX input of the first slave product to the DMX output of the master product.
5. Connect the DMX input of the subsequent slave products to the DMX output of the previous slave product.
6. Finish setting and connecting all the slave products.

Master product:

1. Press **<MENU>** repeatedly until **Addr** shows on the display.
2. Press **<ENTER>**.
3. Set the DMX address to **1**.
4. Set the master product to operate in standalone mode.
5. Make the master product the first product in the DMX daisy chain.



- **Configure all the slave products before connecting the master to the daisy chain.**
- **Never connect a DMX controller to a DMX string configured for Master/Slave operation because the controller may interfere with the signals from the master.**
- **Do not connect more than 31 slaves to the master.**

5. Maintenance

Bubble Cleaning Mode

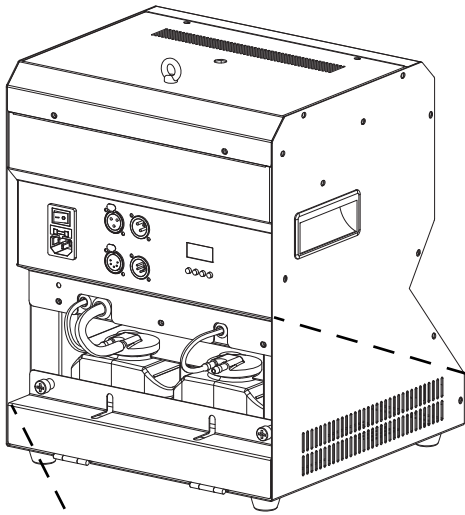

To clean the bubble mechanism with the Bubble Cleaning Mode:

1. Unscrew the cap from the Bubble Fluid Reservoir.
2. Place the In Hose in a container of clean water.
3. Place the Out Hose where it can safely drain.
4. Run the Bubble Cleaning Mode through the menu or DMX.
5. Thoroughly rinse the Bubble Fluid Reservoir.
6. Restore the hoses and cap to the Bubble Fluid Reservoir.
7. The Hurricane Bubble Haze may now be stored until its next use.

NOTE: Use the Bubble Cleaning Mode after every use.

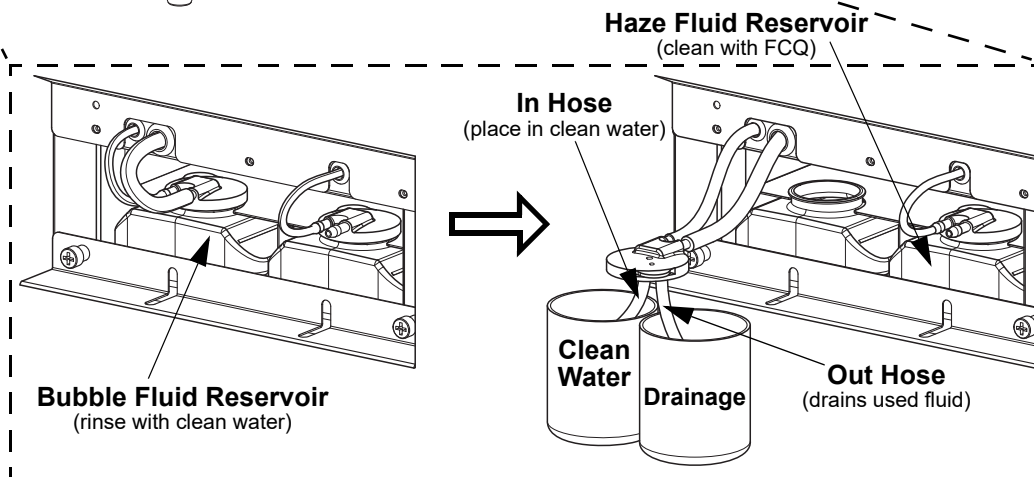

Hazer Maintenance

Do not allow the hazer mechanism to become clogged. After every 40 hours of continuous operation, use CHAUVET Fog Cleaner Quart (FCQ) through the system to prevent the accumulation of particulate matter in the heating element.

The recommended cleaning procedure is as follows.

1. Unplug the product from power.
2. Empty all haze fluid from the machine.
3. Add cleaning solution to the Haze Fluid Reservoir.
4. Connect the product to power and allow it to warm up.
5. Run the unit in a well-ventilated area until the Haze Fluid Reservoir is almost empty. Do not allow the pump to run dry.
6. Refill the Haze Fluid Reservoir with haze fluid to continue using the hazer. Run the machine briefly to clear any remaining cleaning solution from the pump and heater.



Use the [Bubble Cleaning Mode](#) after every use.



Never operate the machine without fluid.



Fog Cleaner Quart (FCQ) was specifically developed by Chauvet to clean your Hurricane Bubble Haze. Make sure you use FCQ regularly, no longer than 90 days between cleanings, to increase the life of your product.



Do not spin the blower fan using compressed air because it could be damaged.

Storage

Before storing the product, run FCQ through the system as described in the cleaning procedure above; however, only follow steps 1 through 5. Do not refill the Haze Fluid Reservoir with haze fluid if storing the product. Cleaning the system prior to storage will help prevent any particles from condensing inside the pump or heater while not in use.

Before storing the product, use the [Bubble Cleaning Mode](#).



Test-run your Hurricane Bubble Haze on a monthly basis to achieve the best performance.

Powering Off the Product for Transport

After using the [Bubble Cleaning Mode](#), follow these instructions to prevent leaks. This will allow the air pump to entirely clear the haze fluid line and heater of the haze fluid before power off.

To prevent spills or leaks before, during, or after transport, Chauvet recommends the following steps for your Hurricane Bubble Haze:



1. Set the "Haze Volume" output to 0.
2. Wait 30-45 seconds.
3. When there is no more haze fluid in the output line, turn off the machine by pressing the power switch.

6. Technical Specifications

Dimensions and Weight

Length	Width	Height	Weight
12.2 in (310 mm)	12.3 in (312 mm)	15.5 in (394 mm)	20.2 lb (9.2 kg)

Note: Dimensions in inches are rounded.

Power

Power Supply Type	Range	Voltage Selection
Fixed	120 VAC, 60 Hz, or 230 VAC, 50 Hz	Fixed
Parameter	120 V, 60 Hz	230 V, 50 Hz
Consumption	558 W	558 W
Operating Current	4.6 A	2.3 A
Fuse	F 7 A, 250 V	F 7 A, 250 V
Power I/O	U.S./Worldwide	UK/Europe
Power input connector	IEC	IEC
Power Cord plug	Edison (U.S.)	Local Plug

Operation

Heat-Up Time	Tank Capacity	Output
3 min	0.21 gal (0.8 l) each	10,000 cfm
Haze Fluid Consumption	Bubble Fluid Consumption	
16 ml/min	22 mm/min	

Thermal

Maximum External Temperature	Cooling System
104 °F (40 °C)	Convection

DMX

I/O Connector	Channel Range
3- and 5-pin XLR	4

Ordering

Product Name	Item Code	UPC Number
Hurricane Bubble Haze (120V)	05071571	781462219192
Hurricane Bubble Haze (230V)	05071574	781462219222



Returns

In case you need to get support or return a product:

- If you are located in the US, contact Chauvet World Headquarters.
- If you are located in the UK or Ireland, contact Chauvet Europe Ltd.
- If you are located in Benelux, contact Chauvet Europe BVBA.
- If you are located in France, contact Chauvet France.
- If you are located in Germany, contact Chauvet Germany.
- If you are located in Mexico, contact Chauvet Mexico.
- If you are located in any other country, DO NOT contact Chauvet. Instead, contact your local distributor. See www.chauvetdj.com for distributors outside the US, UK, Ireland, Benelux, France, Germany, or Mexico.



If you are located outside the US, UK, Ireland, Benelux, France, Germany, or Mexico, contact your distributor of record and follow their instructions on how to return Chauvet products to them. Visit our website www.chauvetdj.com for contact details.

Call the corresponding Chauvet Technical Support office and request a Return Merchandise Authorization (RMA) number before shipping the product. Be prepared to provide the model number, serial number, and a brief description of the cause for the return.

To submit a service request online, go to www.chauvetdj.com/service-request.

Send the merchandise prepaid, in its original box, and with its original packing and accessories. Chauvet will not issue call tags.

Clearly label the package with the RMA number. Chauvet will refuse any product returned without an RMA number.



Write the RMA number on a properly affixed label. DO NOT write the RMA number directly on the box.

Before sending the product, clearly write the following information on a piece of paper and place it inside the box:

- Your name
- Your address
- Your phone number
- RMA number
- A brief description of the problem

Be sure to pack the product properly. Any shipping damage resulting from inadequate packaging will be your responsibility. FedEx packing or double-boxing are recommended.



Chauvet reserves the right to use its own discretion to repair or replace returned product(s).

Contact Us

General Information	Technical Support
Chauvet World Headquarters	
Address: 5200 NW 108th Ave. Sunrise, FL 33351 Voice: (954) 577-4455 Fax: (954) 929-5560 Toll Free: (800) 762-1084	Voice: (844) 393-7575 Fax: (954) 756-8015 Email: chauvetcs@chauvetlighting.com Website: www.chauvetdj.com
Chauvet Europe Ltd	
Address: Unit 1C Brookhill Road Industrial Estate Pinxton, Nottingham, UK NG16 6NT Voice: +44 (0) 1773 511115 Fax: +44 (0) 1773 511110	Email: UKtech@chauvetlighting.eu Website: www.chauvetdj.eu
Chauvet Europe BVBA	
Address: Stokstraat 18 9770 Kruishoutem Belgium Voice: +32 9 388 93 97	Email: BNLtech@chauvetlighting.eu Website: www.chauvetdj.eu
Chauvet France	
Address: 3, Rue Ampère 91380 Chilly-Mazarin France Voice: +33 1 78 85 33 59	Email: FRtech@chauvetlighting.fr Website: www.chauvetdj.eu
Chauvet Germany	
Address: Bruno-Bürgel-Str. 11 28759 Bremen Germany Voice: +49 421 62 60 20	Email: DEtech@chauvetlighting.de Website: www.chauvetdj.eu
Chauvet Mexico	
Address: Av. de las Partidas 34 - 3B (Entrance by Calle 2) Zona Industrial Lerma Lerma, Edo. de México, CP 52000 Voice: +52 (728) 690-2010	Email: servicio@chauvet.com.mx Website: www.chauvetdj.mx

Visit the applicable website above to verify our contact information and instructions to request support. Outside the US, UK, Ireland, Mexico, France, Germany, or Benelux, contact the dealer of record.